

Y STARINER 215

- Body construction 215 Y 2"-24"
- Face to face BS.16.10
- Flanges EN 1092-2 / AS-2124(D)(BS10)
- Max working pressure PN 16
- Temperature range -20°C + 140°C according to material
- Coating Epoxy min 80 micron UV resistance
- Tightness test According to EN 12266-1:2003
- Material certificate EN 10204.3.1
- Screen 2"-8" 50% holes of Ø 3 mm
10"-24" 50% holes of Ø 5 mm



Materials Model 215

Item	Description	Material
1	Body	Ductile Iron/ Cast Iron
2	Cover	ST-37/ Ductile Iron/ Cast Iron
3	Screen	SS304/ 316
4	Screw/Nut	SS/ Galvanized steel
5	Gasket	NBR/ EPDM
6	Plug	Galvanized steel

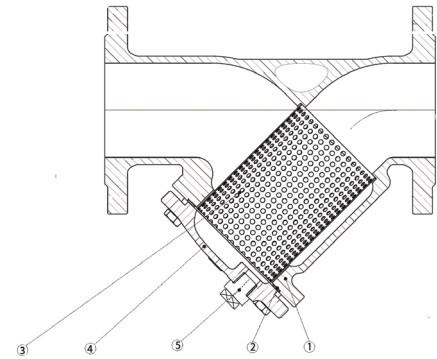

Dimensions Model 215

mm	50	60	80	100	150	200	250	300	350	400	500	600
Inches	2"	2.5"	3"	4"	6"	8"	10"	12"	14"	16"	20"	24"
L	203	222	241	305	394	457	533	610	686	762	914	1067
D	165	185	200	218	285	340	405	460	520	580	715	840
D2	125	145	160	180	240	295	350 355	400 410	470	525	650	770
b	19	19	19	19	19	20	22	24.5	26.5	28	31.5	36
H	113	130	157	187	278	349	435	520	605	690	870	960

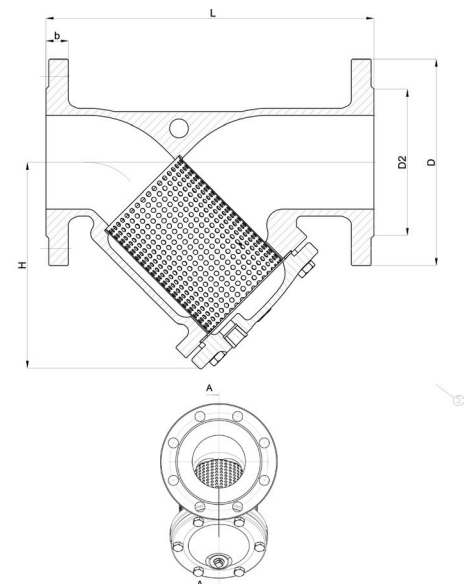

Note: Due to company's policy of continuous improvement, Hakohav Valves reserves the right to change specification without prior notice.